

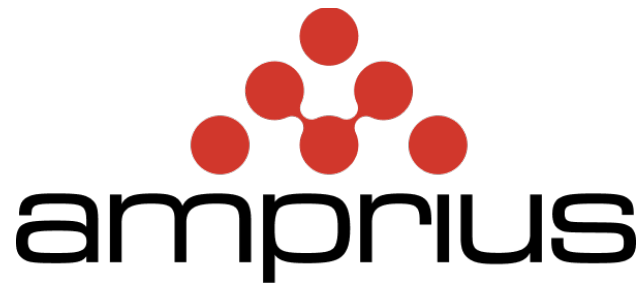

Silicon Anode Li-Ion Cell Product Portfolio





Amprius Technologies, Inc. is a leading manufacturer of high-energy and high-power lithium-ion batteries, producing the industry's highest-known energy density cells. The company's commercially available SiMaxx™ batteries deliver up to 450 Wh/kg and 1,150 Wh/L, with third-party validation of 500Wh/kg and 1,300 Wh/L. Amprius expanded its product portfolio to include the SiCore™ platform in 2024, which delivers up to 400 Wh/kg, significantly enhancing its ability to serve additional customer applications.

The company's corporate headquarters is in Fremont, California, where it maintains an R&D lab and a MWh scale manufacturing facility for the fabrication of silicon anodes and cells. To serve customer demand, Amprius entered into several agreements to secure over 500MW/h of contract manufacturing available today and entered into a lease agreement for a gigawatt-hour-scale facility in Brighton, Colorado.



SA02

SiCore™ | Rechargeable Lithium-Ion Cell



11.25 Ah Energy + Power Balanced Cell

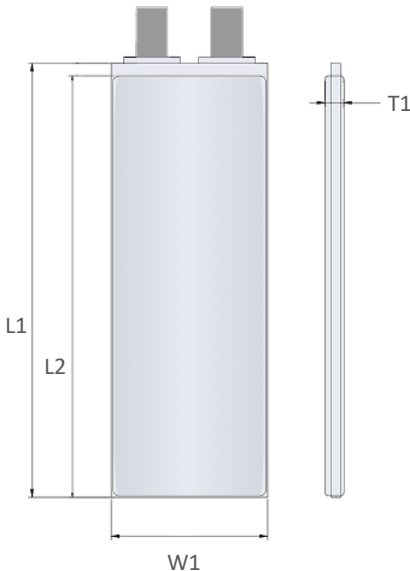

Specifications

Capacity	Typical @ C/5	11250 mAh
		39.38 Wh
	Minimum	11000 mAh
		38.50 Wh
Cell Voltage	Nominal	3.50 V
	Charge	4.20 V
	Discharge	2.50 V
Discharge Current	Max Continuous	33.0 A (3C)
	Max Pulse (≤ 30 seconds)	55.0 A (5C)
Charge Current	Typical	2.20 A (C/5)
	Maximum (0% to 100% SOC)	11.0 A (1C)
Temperature Range Ambient	Discharge	-20 to 55°C
	Charge	0 to 55°C
	Storage	-20 to 30°C
Internal Resistance	ACIR (1 kHz @ 30% SOC)	≤ 10 m Ω
	DCIR	N/A
Cycle Life	+1C/-1C, 100% DOD to 80% SOH	700 cycles
	+1C/-1C, 90% DOD to 80% SOH	1000 cycles
Weight		111.2 \pm 2g
Packaging		Pouch
Cathode		NMC
Energy Density Including packaging	Gravimetric	355 Wh/kg
	Volumetric (@ 30% SOC)	805 Wh/l
Certifications		UN 38.3, IEC 62133, BIS

Dimensions

Size	L1	139.3 \pm 0.4mm
	L2	134.3 \pm 0.8mm
	W1	52.1 \pm 1.2mm
	T1 (@ 30% SOC)	6.74 \pm 0.25mm

Technical Data Sheet | AMP-TDS-SA02-R3

Fremont, CA | inquire@amprius.com

©2024 Amprius Technologies, Inc. | www.amprius.com | All information is subject to change without notice

SA02

SiCore™ | Rechargeable Lithium-Ion Cell

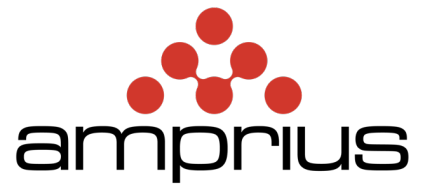

11.25 Ah Energy + Power Balanced Cell

Discharge Rate Capability

At Room Temperature

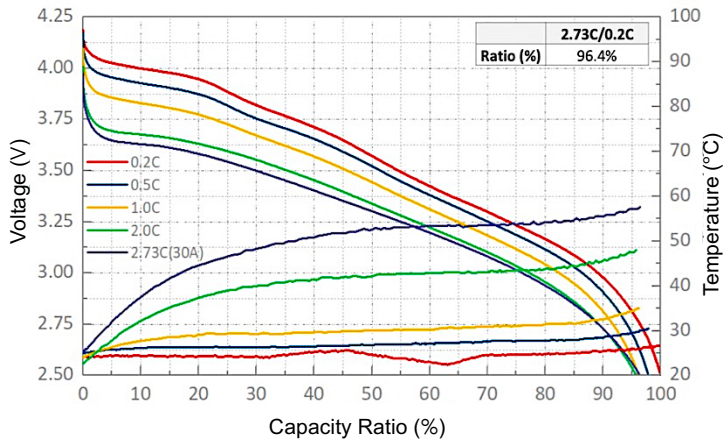

Cycle Life Performance

At Room Temperature

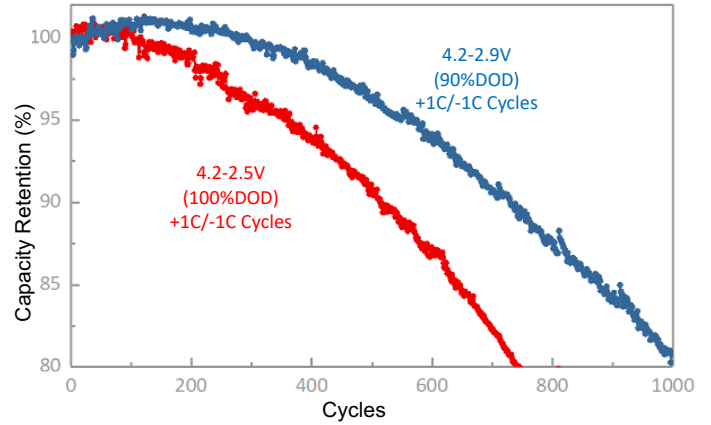

Charge Rate Profiles

Room Temperature at 1C, 2C, 3C

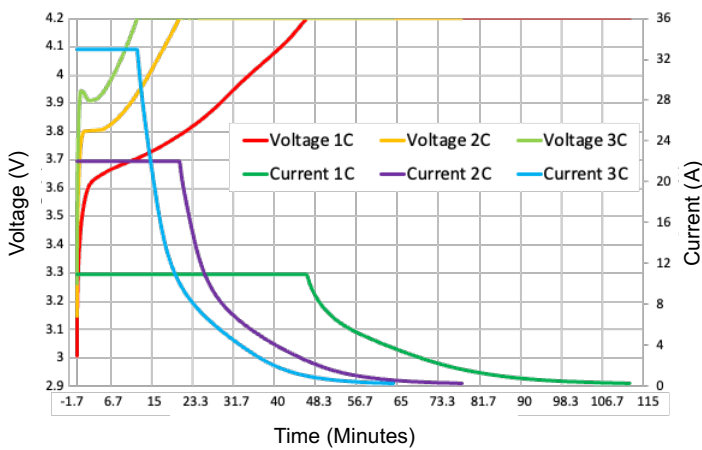

High/Low Temperature Discharge Performance

Discharge Capacity (Ah) @ 0.2C vs. Voltage (V) at various temperatures

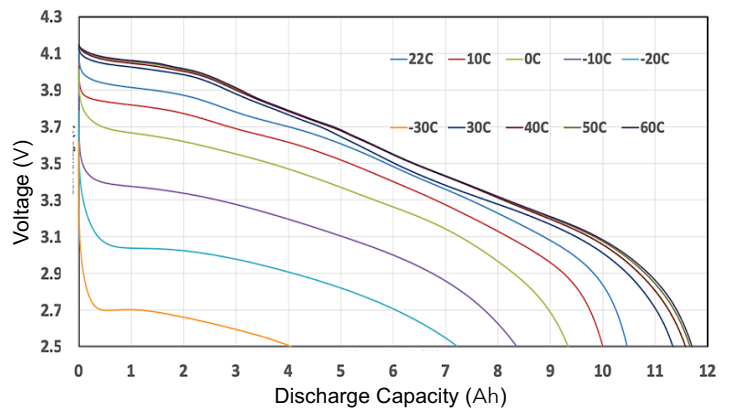

Technical Data Sheet | AMP-TDS-SA02-R3

Fremont, CA | inquire@amprius.com

©2024 Amprius Technologies, Inc. | www.amprius.com | All information is subject to change without notice

SA03

SiCore™ | Rechargeable Lithium-Ion Cell

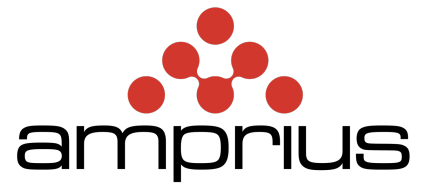

11.9 Ah Energy Cell

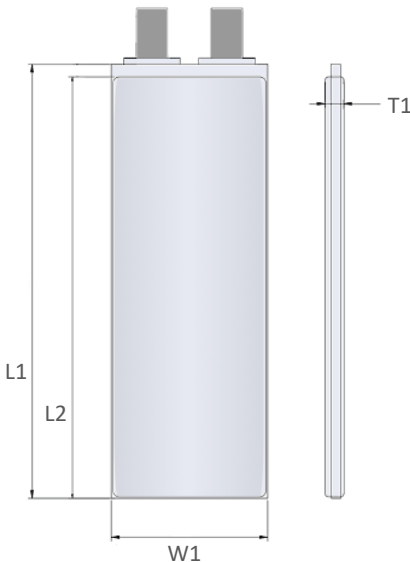

Specifications

Capacity	Typical @ C/5	11840 mAh
		40.26 Wh
	Minimum	11600 mAh
		39.44 Wh
Cell Voltage	Nominal	3.40 V
	Charge	4.20 V
	Discharge	2.50 V
Discharge Current	Max Continuous	11.6 A (1C)
	Max Pulse (≤ 30 seconds)	34.8 A (3C)
Charge Current	Typical	2.36 A (C/5)
	Maximum (0% to 100% SOC)	3.93 A (C/3)
Temperature Range Ambient	Discharge	-20 to 55°C
	Charge	10 to 55°C
	Storage	-20 to 45°C
Internal Resistance	ACIR (1 kHz @ 30% SOC)	≤ 20 m Ω
	DCIR	N/A
Cycle Life	+0.3C/-1C, 100% DOD to 80% SOH	300 cycles
	+0.3C/-1C, 70% DOD to 90% SOH	700 cycles
Weight		102.0 \pm 2g
Packaging		Pouch
Cathode		NMC
Energy Density Including packaging	Gravimetric	400 Wh/kg
	Volumetric (@ 30% SOC)	872 Wh/l
Special Note	External clamping of 15 PSI is recommended	
Certifications	UN 38.3	

Dimensions

Size	L1	139.0 \pm 0.6mm
	L2	134.3 \pm 0.8mm
	W1	52.5 \pm 1.5mm
	T1 (@ 30% SOC)	6.32 \pm 0.25mm

Technical Data Sheet | AMP-TDS-SA03-R3

Fremont, CA | inquire@amprius.com

©2024 Amprius Technologies, Inc. | www.amprius.com | All information is subject to change without notice

SA03

SiCore™ | Rechargeable Lithium-Ion Cell

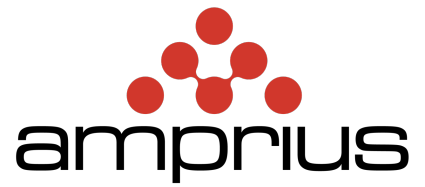

11.9 Ah Energy Cell

Discharge Rate Capability

At Room Temperature

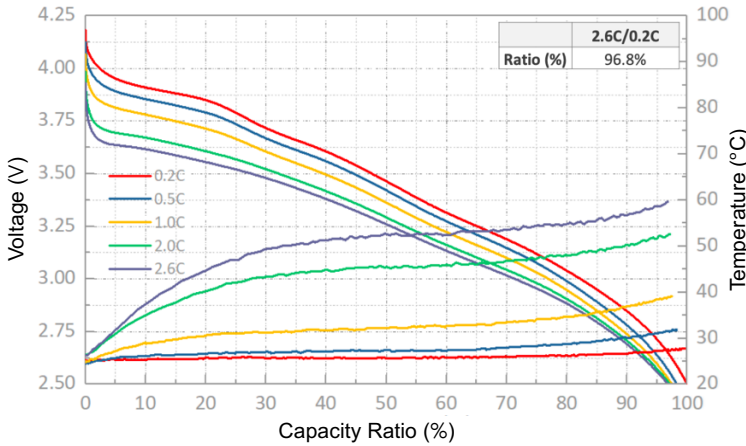

Cycle Life Performance

At Room Temperature

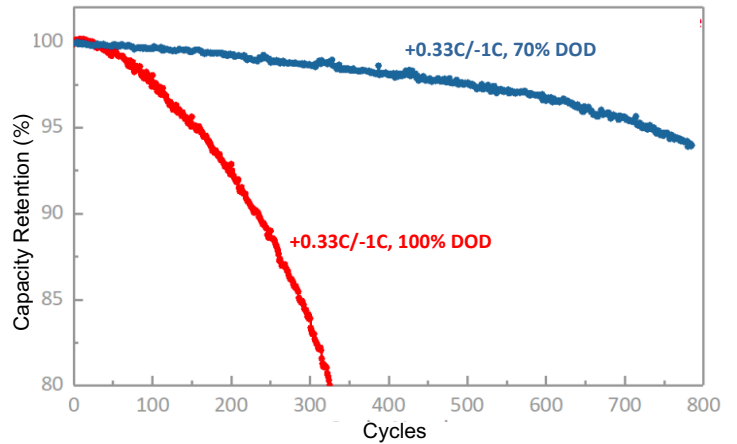

Charge Rate Profiles

Room Temperature at C/5, C/2, 1C

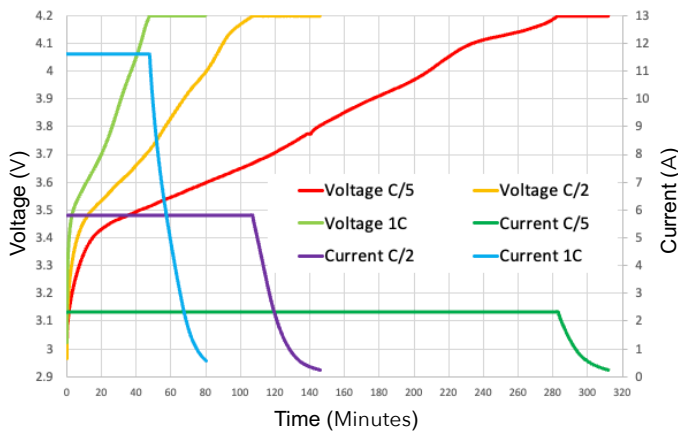

High/Low Temperature Discharge Performance

Discharge Capacity (Ah) @ 0.2C vs. Voltage (V) at various temperatures

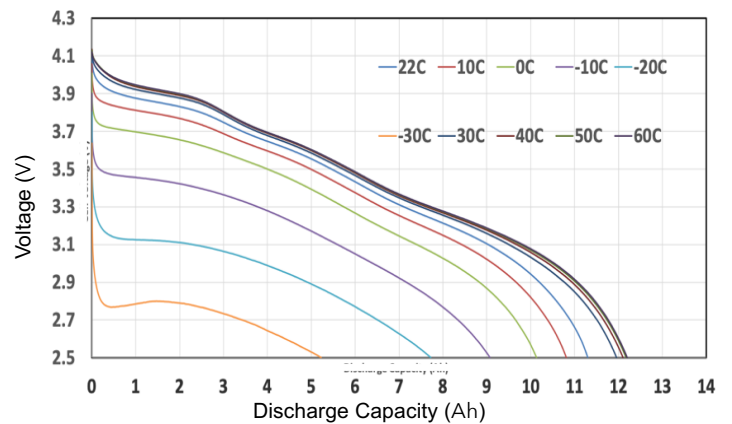

Technical Data Sheet | AMP-TDS-SA03-R3

Fremont, CA | inquire@amprius.com

©2024 Amprius Technologies, Inc. | www.amprius.com | All information is subject to change without notice

SA04

SiCore™ | Rechargeable Lithium-Ion Cell



8.9 Ah Long Cycle Life Cell

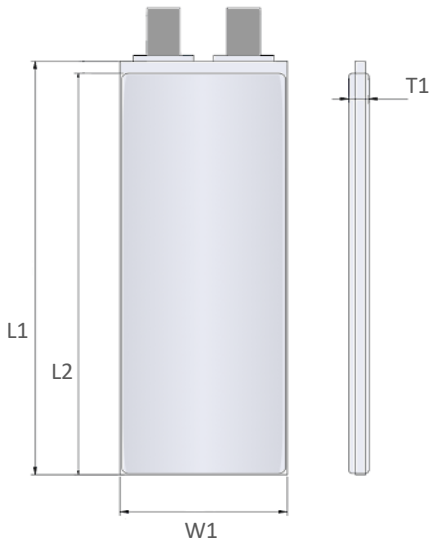

Specifications

Capacity	Typical @ C/5	8900 mAh
		32.04 Wh
	Minimum	8767 mAh
		31.56 Wh
Cell Voltage	Nominal	3.60 V
	Charge	4.20 V
	Discharge	2.50 V
Discharge Current	Max Continuous	26.7 A (3C)
	Max Pulse (≤ 30 seconds)	26.7 A (3C)
Charge Current	Typical	1.78 A (C/5)
	Maximum (0% to 100% SOC)	4.45 A (C/2)
Temperature Range Ambient	Discharge	-20 to 55°C
	Charge	0 to 55°C
	Storage	-20 to 30°C
Internal Resistance	ACIR (1 kHz @ 30% SOC)	≤ 8 m Ω
	DCIR	N/A
Cycle Life	+1C/-1C, 100% DOD to 80% SOH	1400 cycles
	+1C/-1C, 87% DOD to 80% SOH	3000 cycles
Weight		102.8 \pm 1g
Packaging		Pouch
Cathode		NMC
Energy Density Including packaging	Gravimetric	320 Wh/kg
	Volumetric (@ 30% SOC)	680 Wh/l
Certifications		UN 38.3

Dimensions

Size	L1	139.1 \pm 0.5mm
	L2	133.0 \pm 1.2mm
	W1	52.1 \pm 1.2mm
	T1 (@ 30% SOC, Fresh)	6.5 \pm 0.3mm

Technical Data Sheet | AMP-TDS-SA04-R3

Fremont, CA | inquire@amprius.com

©2024 Amprius Technologies, Inc. | www.amprius.com | All information is subject to change without notice

SA04

SiCore™ | Rechargeable Lithium-Ion Cell

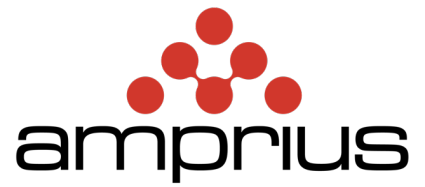

8.9 Ah Long Cycle Life Cell

Discharge Rate Capability

At Room Temperature

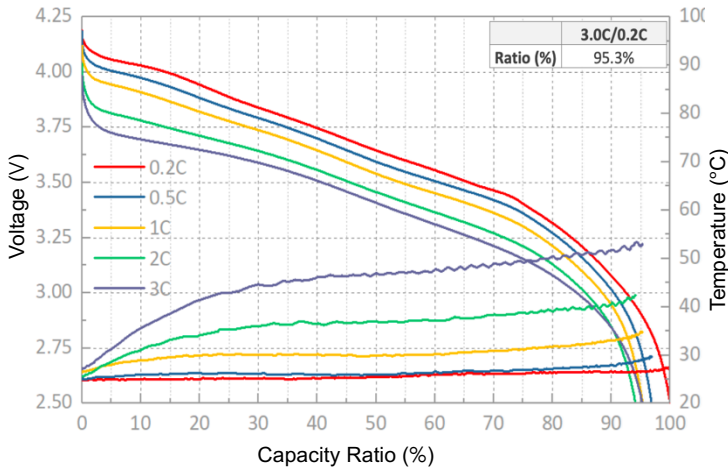

Cycle Life Performance

At Room Temperature

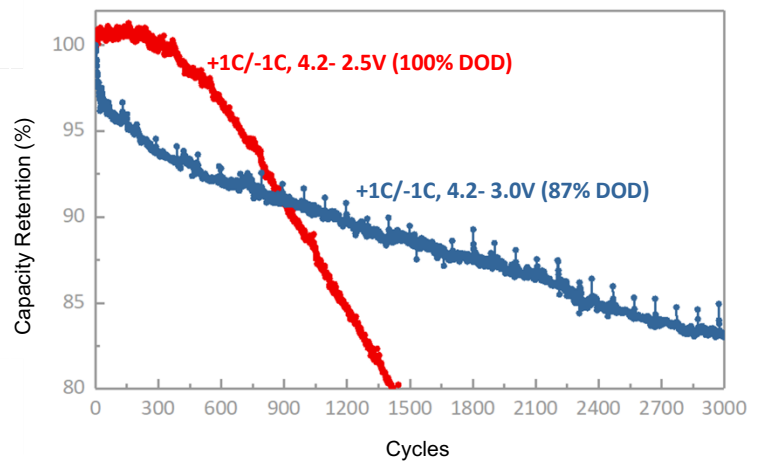

Charge Rate Profiles

Room temperature at C/5, C/3 & 1C Rates

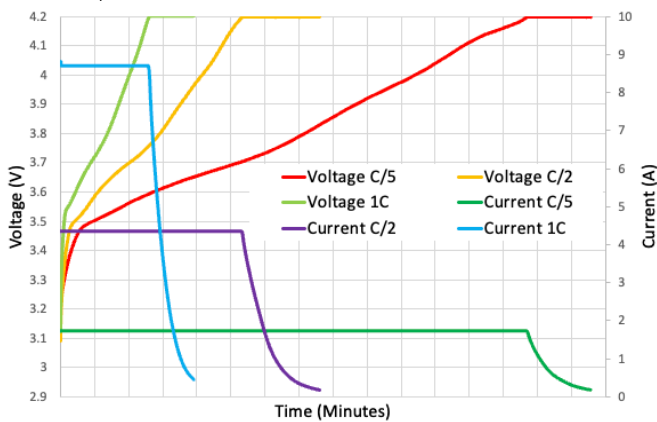

High/Low Temperature Discharge Performance

Discharge Capacity (Ah) @ 0.2C vs. Voltage (V) at various temperatures

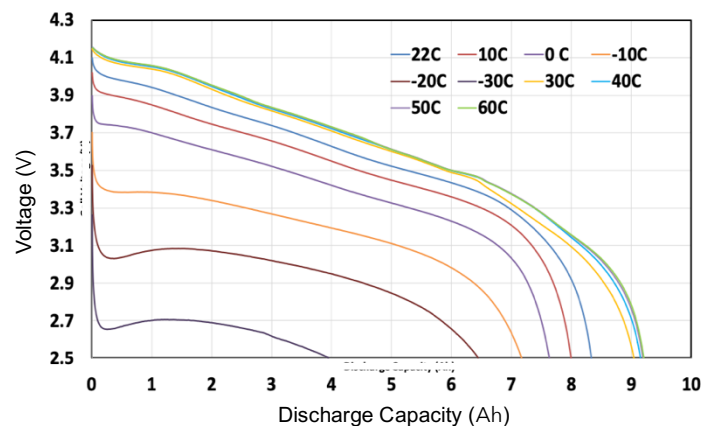

Technical Data Sheet | AMP-TDS-SA04-R3

Fremont, CA | inquire@amprius.com

©2024 Amprius Technologies, Inc. | www.amprius.com | All information is subject to change without notice

SA08

SiCore™ | Rechargeable Lithium-Ion Cell



11.05 Ah Power Cell

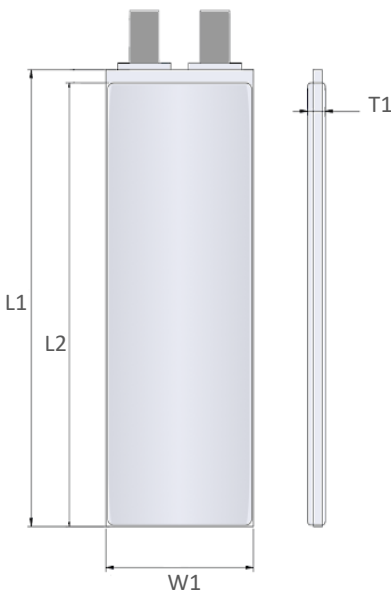

Specifications

Capacity	Typical @ C/5	11050 mAh
		37.57 Wh
	Minimum	10800 mAh
		36.72 Wh
Cell Voltage	Nominal	3.40 V
	Charge	4.20 V
	Discharge	2.50 V
Discharge Current	Max Continuous	54.0 A (5C)
	Max Pulse (≤ 30 seconds)	86.4 A (8C)
Charge Current	Typical	2.16 A (C/5)
	Maximum (0% to 100% SOC)	32.4 A (3C)
Temperature Range Ambient	Discharge	-20 to 60°C
	Charge	0 to 60°C
	Storage	-20 to 45°C
Internal Resistance	ACIR (1 kHz @ 30% SOC)	$\leq 6\text{m}\Omega$
	DCIR	N/A
Cycle Life	+1C/-3C, 100% DOD to 80% SOH	300 cycles
	+1C/-3C, 70% DOD to 90% SOH	700 cycles
Weight		106.5 \pm 2g
Packaging		Pouch
Cathode		NMC
Energy Density Including packaging	Gravimetric	360 Wh/kg
	Volumetric (@ 30% SOC)	800 Wh/l
Certifications		UN 38.3, IEC 62133

Dimensions

Size	L1	144.5 \pm 1.0mm
	L2	134.3 \pm 0.8mm
	W1	52.0 \pm 1.5mm
	T1 (@ 30% SOC)	6.25 \pm 0.25mm

Technical Data Sheet | AMP-TDS-SA08-R4

Fremont, CA | inquire@amprius.com

©2024 Amprius Technologies, Inc. | www.amprius.com | All information is subject to change without notice

SA08

SiCore™ | Rechargeable Lithium-Ion Cell

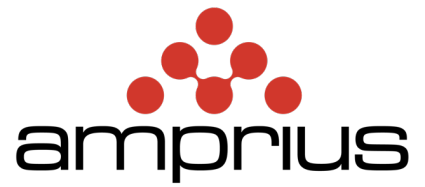

11.05 Ah Power Cell

Discharge Rate Capability

At Room Temperature

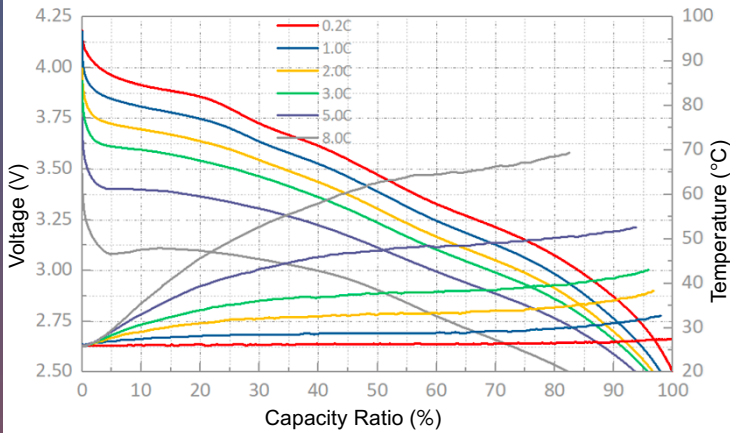

Cycle Life Performance

At Room Temperature

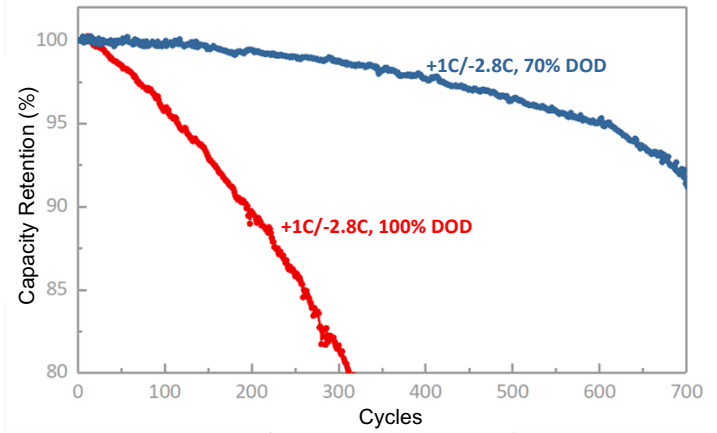

Charge Profiles

Room Temperature at 1C, 2C, 3C, & 4C Rates

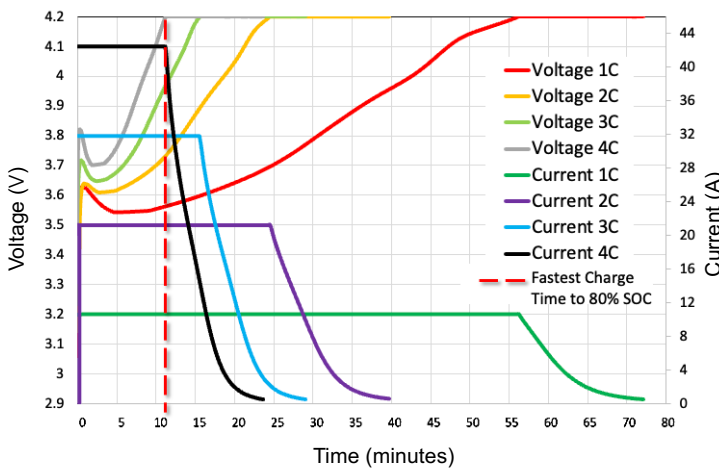

High/Low Temperature Discharge Performance

Discharge Capacity (Ah) @ 0.2C Vs Voltage (V) at various temperatures

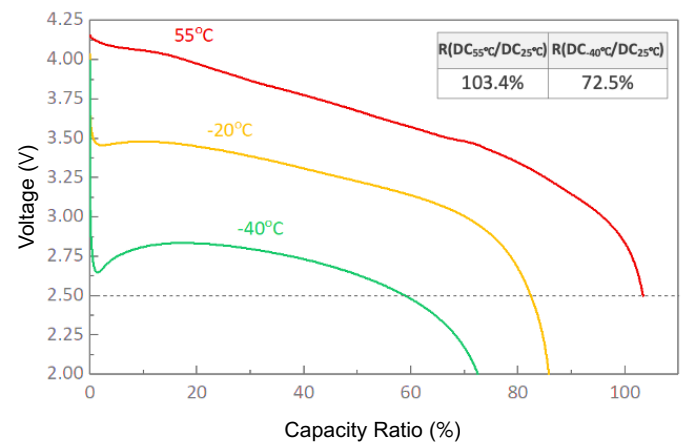

Technical Data Sheet | AMP-TDS-SA08-R4

Fremont, CA | inquire@amprius.com

©2024 Amprius Technologies, Inc. | www.amprius.com | All information is subject to change without notice

SA09

SiCore™ | Rechargeable Lithium-Ion Cell



8.18 Ah Energy Cell

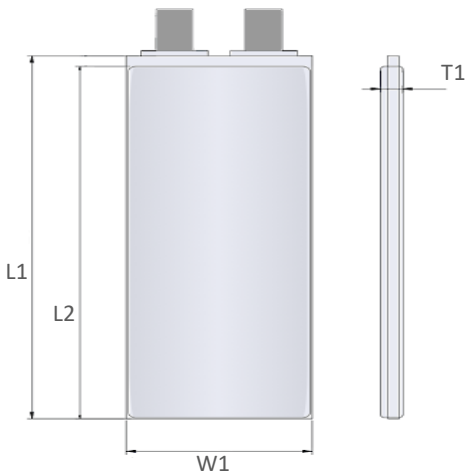

Specifications

Capacity	Typical @ C/5	8180 mAh
		27.81 Wh
	Minimum	8000 mAh
		27.20 Wh
Cell Voltage	Nominal	3.40 V
	Charge	4.20 V
	Discharge	2.50 V
Discharge Current	Max Continuous	8.0 A (1C)
	Max Pulse (≤ 30 seconds)	24.0 A (3C)
Charge Current	Typical	1.6 A (C/5)
	Maximum (0% to 100% SOC)	1.6 (C/5)
Temperature Range Ambient	Discharge	-20 to 60°C
	Charge	10 to 55°C
	Storage	-20 to 45°C
Internal Resistance	ACIR (1 kHz @ 30% SOC)	≤ 10 m Ω
	DCIR	N/A
Cycle Life	+0.3C/-1C to 80% SOH, No Clamping	150 cycles
	+0.3C/-1C to 90% SOH, 15 PSI	150 cycles
Weight		72.5 \pm 2g
Packaging		Pouch
Cathode		NMC
Energy Density Including packaging	Gravimetric	385 Wh/kg
	Volumetric (@ 30% SOC)	805 Wh/l
Special Note	Cell requires external clamping of 15 PSI	
Certifications	UN 38.3	

Dimensions

Size	L1	96.5 \pm 1mm
	L2	90.0 \pm 1mm
	W1	57.5 \pm 2mm
	T1 (@ 30% SOC)	6.23 \pm 0.4mm

Technical Data Sheet | AMP-TDS-SA09-R2

Fremont, CA | inquire@amprius.com

©2024 Amprius Technologies, Inc. | www.amprius.com | All information is subject to change without notice

SA09

SiCore™ | Rechargeable Lithium-Ion Cell

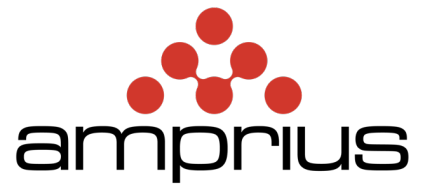

8.18 Ah Energy Cell

Discharge Rate Capability

At Room Temperature

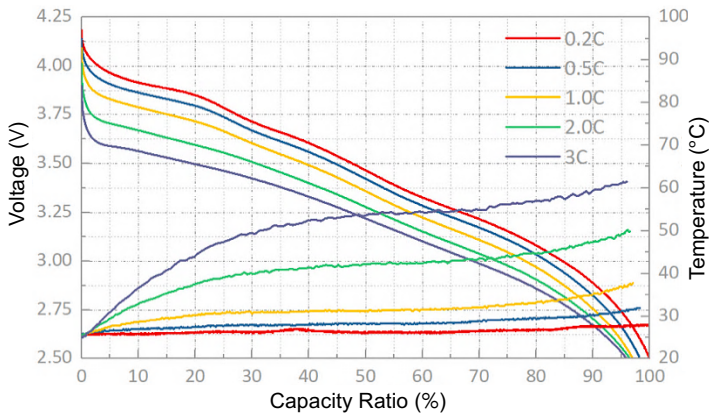

Cycle Life Performance

At Room Temperature

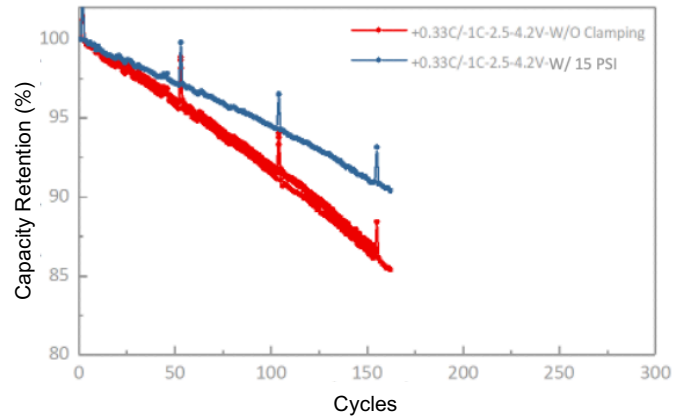

Charge Rate Profiles

Room Temperature at C/10, C/5, 1C, 2C & 3C

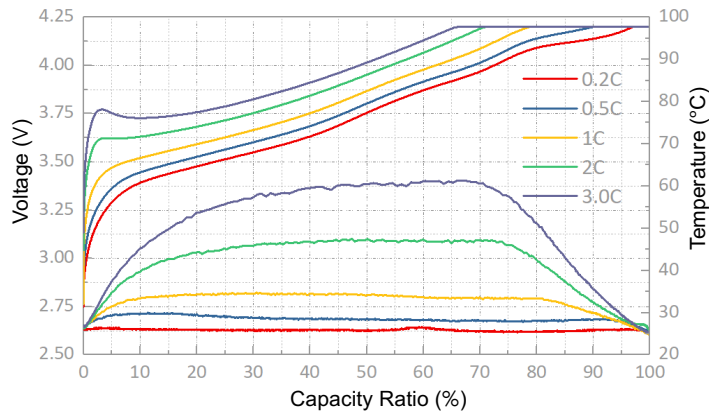

High/Low Temperature Discharge Performance

Discharge Capacity Ratio of +0.5C/-0.2C at Various Temperatures

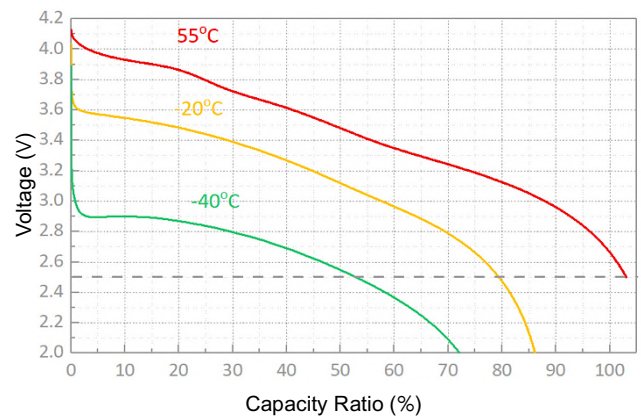

SA10

SiCore™ | Rechargeable Lithium-Ion Cell

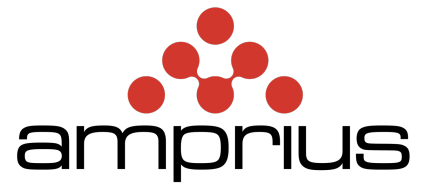

4Ah Energy + Mid Power 18650 Cell

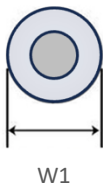
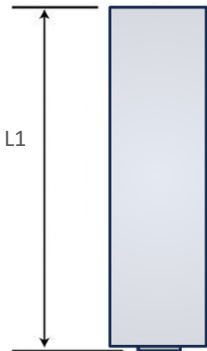

Specifications

Capacity	Typical	4000 mAh 14.4 Wh
	Minimum	3850 mAh 13.86 Wh
Cell Voltage	Nominal	3.60 V
	Charge	4.20 V
	Discharge	2.50 V
Discharge Current	Max Continuous	12 A (3C)
	Max Pulse (≤ 30 seconds)	20 A (5C)
Charge Current	Typical	2 A (C/2)
	Maximum (0% to 100% SOC)	4 A (1C)
Temperature Range Ambient	Discharge	-20 to 60°C
	Charge	0 to 45°C
Internal Resistance	ACIR (1 kHz @ 30% SOC)	≤ 25 m Ω
	DCIR	N/A
Cycle Life	+0.5C / -1C, 4.2 to 2.75V	600 cycles
Weight		48 \pm 2 g
Packaging		18650 Cylindrical
Cathode		NMC
Energy Density	Gravimetric	300 Wh/kg
	Volumetric	830 Wh/l
Certifications		UN 38.3, IEC 62133*, UL1642*, PSE*

Dimensions

Size	L1	65.05 \pm 0.15mm
	W1	18.35 \pm 0.15mm

SA10

SiCore™ | Rechargeable Lithium-Ion Cell

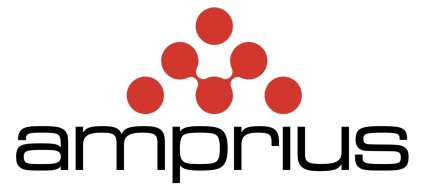

4Ah Energy + Mid Power 18650 Cell

Discharge Rate Capability

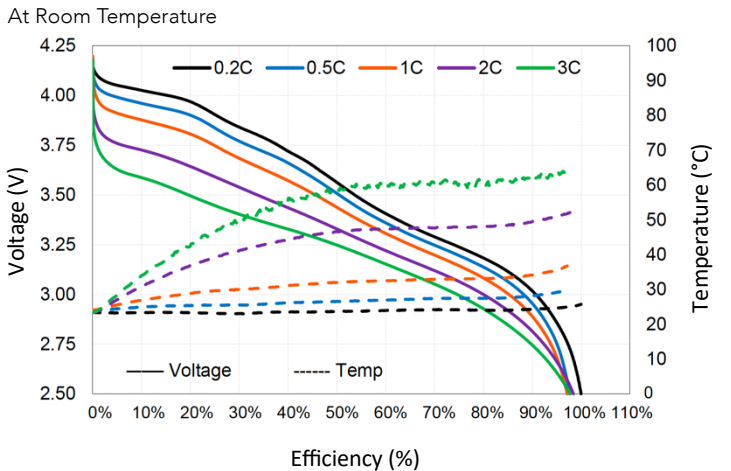

Cycle Life Performance

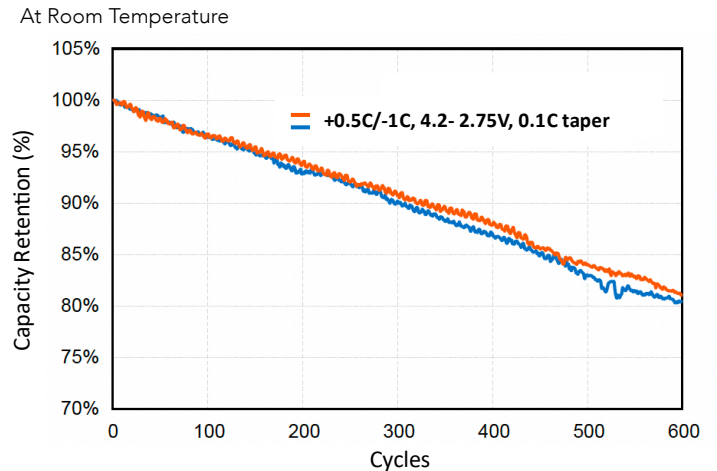

Charge Rate Capability

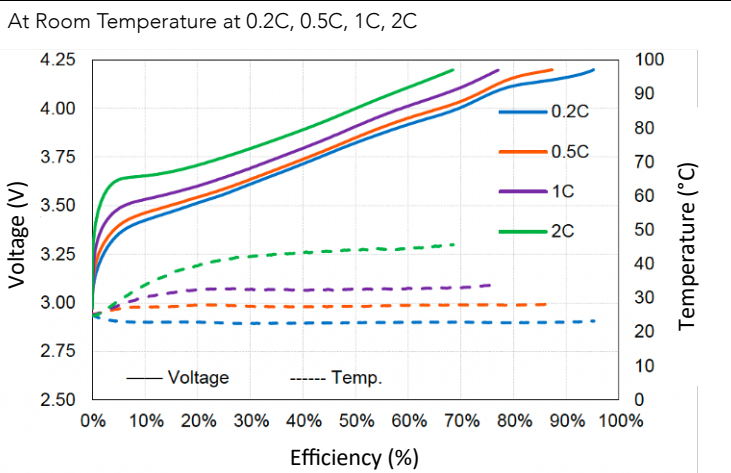

High/Low Temperature Discharge Performance

Discharge Capacity (Ah) @ 1C vs. Voltage (V) at various temperatures

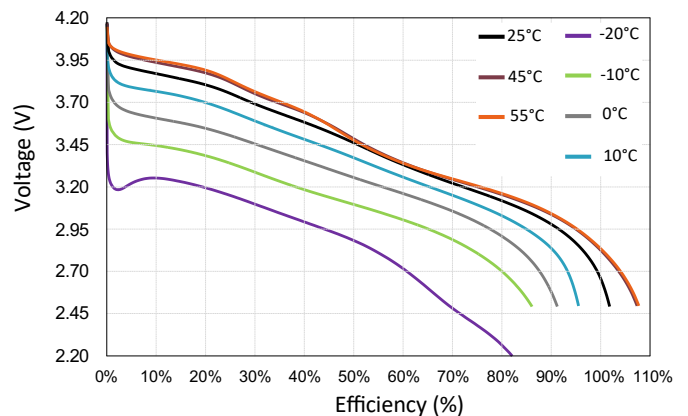

Technical Data Sheet | AMP-TDS-SA10-R1

Fremont, CA | inquire@amprius.com

©2024 Amprius Technologies, Inc. | www.amprius.com | All information is subject to change without notice

SA11

SiCore™ | Rechargeable Lithium-Ion Cell



30.75 Ah Energy + Power Balanced Cell

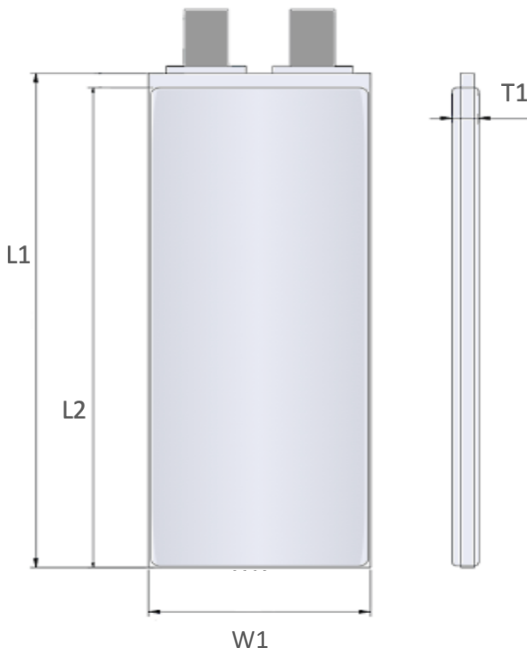

Specifications

Capacity	Typical @ C/5	30750 mAh
		107.6 Wh
	Minimum	30000 mAh
		105.0 Wh
Cell Voltage	Nominal	3.50 V
	Charge	4.20 V
	Discharge	2.50 V
Discharge Current	Max Continuous	90 A (3C)
	Max Pulse (≤ 30 seconds)	150 A (5C)
Charge Current	Typical	6 A (C/5)
	Maximum (0% to 100% SOC)	30 A (1C)
Temperature Range Ambient	Discharge	-20 to 55°C
	Charge	0 to 55°C
	Storage	-20 to 30°C
Internal Resistance	ACIR (1 kHz @ 30% SOC)	≤ 8 m Ω
	DCIR	N/A
Cycle Life	+1C/-1C, 100% DOD to 80% SOH	700 cycles
	+1C/-1C, 90% DOD to 80% SOH	1000 cycles
Weight		305 \pm 9g
Packaging		Pouch
Cathode		NMC
Energy Density Including packaging	Gravimetric	353 Wh/kg
	Volumetric (@ 30% SOC)	790 Wh/l
Certifications		UN 38.3

Dimensions

Size	L1	198.0 \pm 1.5mm
	L2	190.0 \pm 1.5mm
	W1	98.0 \pm 1.5mm
	T1 (@ 30% SOC)	7.0 \pm 0.3mm

Technical Data Sheet | AMP-TDS-SA11-R1

Fremont, CA | inquire@amprius.com

©2024 Amprius Technologies, Inc. | www.amprius.com | All information is subject to change without notice

SA11

SiCore™ | Rechargeable Lithium-Ion Cell



30.75 Ah Energy + Power Balanced Cell

Discharge Rate Capability

At Room Temperature

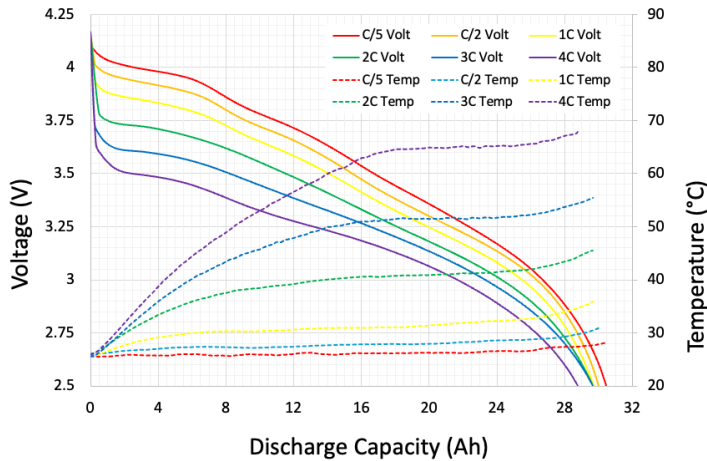

Cycle Life Performance

At Room Temperature

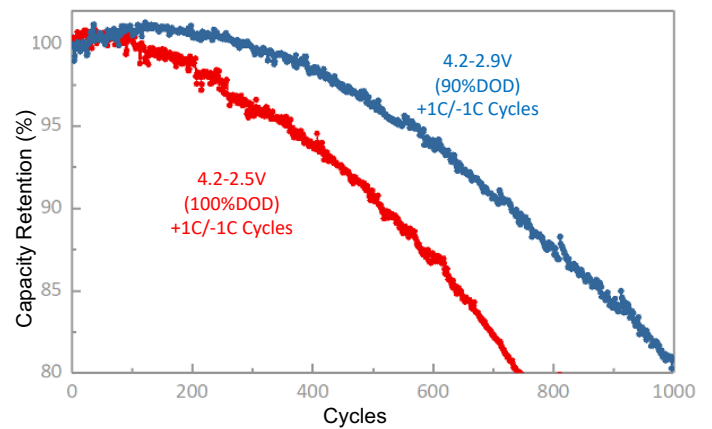

Charge Rate Profiles

Room Temperature at C/5, C/2, 1C

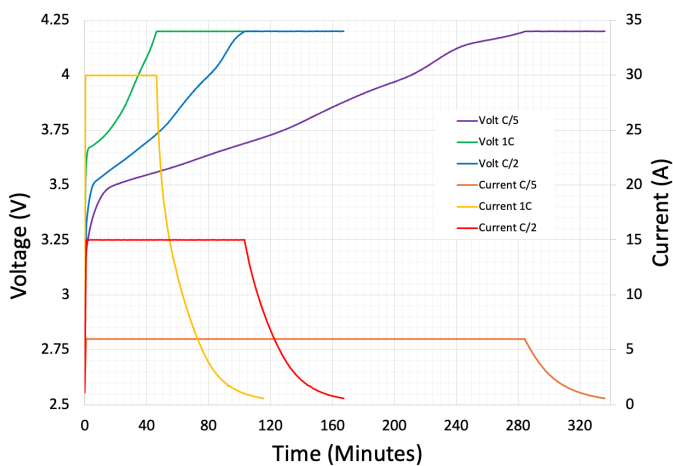

High/Low Temperature Discharge Performance

Discharge Capacity (Ah) @ 1C vs. Voltage (V) at various temperatures

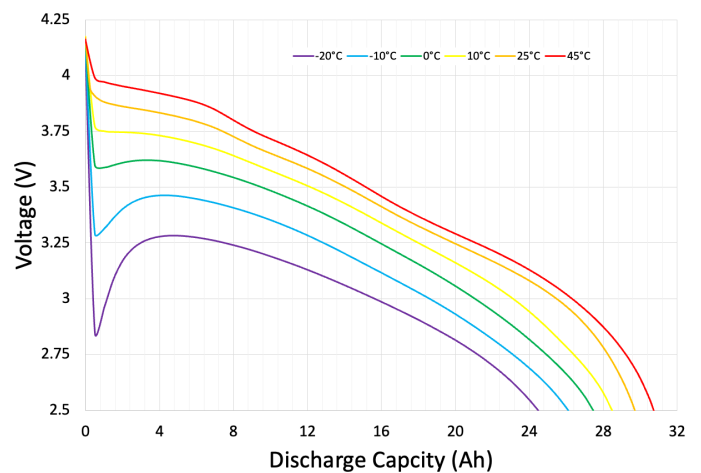

Technical Data Sheet | AMP-TDS-SA11-R1

Fremont, CA | inquire@amprius.com

©2024 Amprius Technologies, Inc. | www.amprius.com | All information is subject to change without notice

SA17

SiCore™ | Rechargeable Lithium-Ion Cell

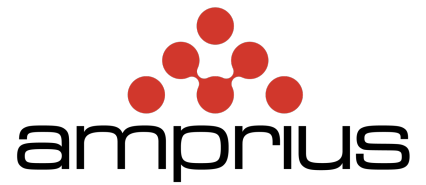

6Ah Energy + Mid Power 21700 Cell

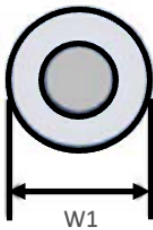

Specifications

Capacity	Typical	6000 mAh
		21.6 Wh
	Minimum	5850 mAh
		21.06 Wh
Cell Voltage	Nominal	3.60 V
	Charge	4.20 V
	Discharge	2.50 V
Discharge Current	Max Continuous	18 A (3C)
	Max Pulse (≤ 30 seconds)	30 A (5C)
Charge Current	Typical	3 A (C/2)
	Maximum (0% to 100% SOC)	6 A (1C)
Temperature Range Ambient	Discharge	-20 to 60°C
	Charge	0 to 45°C
Internal Resistance	ACIR (1 kHz @ 30% SOC)	≤ 25 m Ω
Cycle Life	+0.5C / -1C, 4.2 to 2.75V	600 cycles
Weight		74 \pm 1 g
Packaging		21700 Cylindrical
Cathode		NMC
Energy Density	Gravimetric	300 Wh/kg
	Volumetric	830 Wh/l
Certifications*	UN38.3, IEC 62133*, UL 1642*	

Dimensions

Size	L1	70.95 \pm 0.2mm
	W1	21.65 \pm 0.2mm

*4Q24

Technical Data Sheet | AMP-TDS-SA17-R2

Fremont, CA | inquire@amprius.com

©2024 Amprius Technologies, Inc. | www.amprius.com | All information is subject to change without notice

SA17

SiCore™ | Rechargeable Lithium-Ion Cell

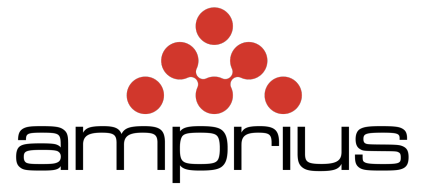

6Ah Energy + Mid Power 21700 Cell

Discharge Rate Capability

At Room Temperature

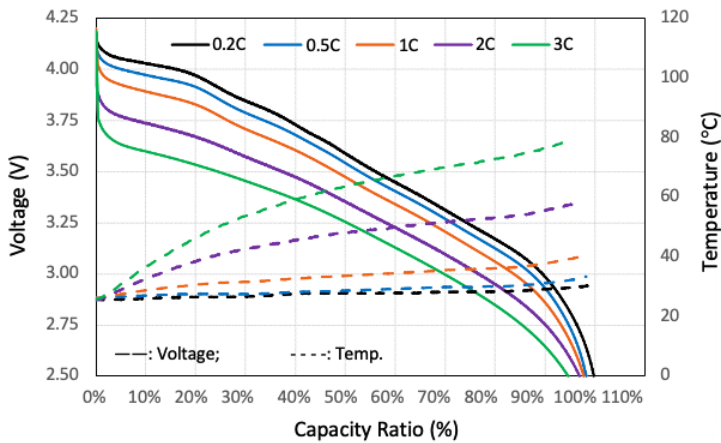

Cycle Life Performance

At Room Temperature

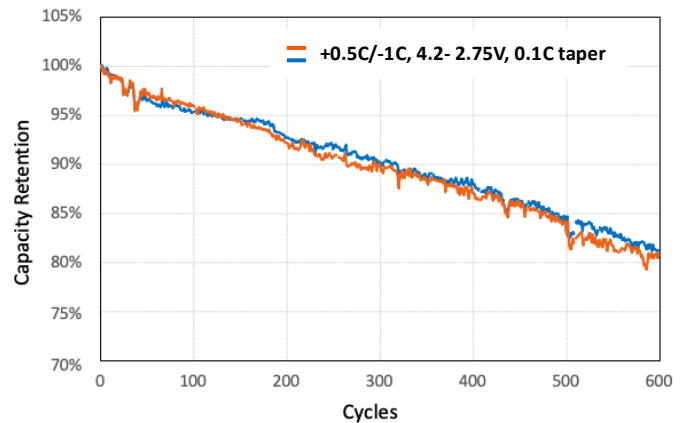

Charge Rate Capability

At Room Temperature at 0.2C, 0.5C, 1C, 2C

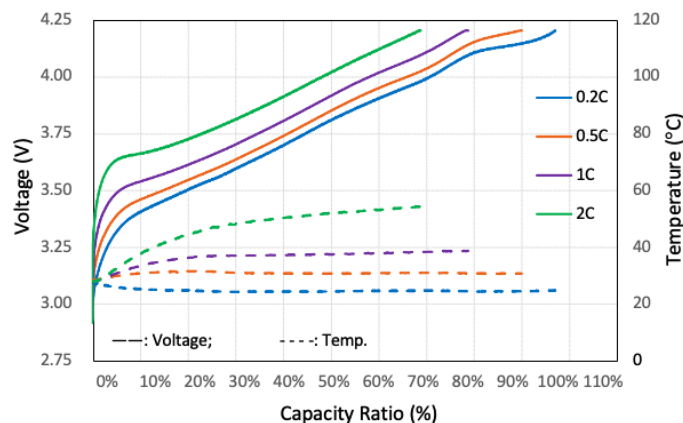

High/Low Temperature Discharge Performance

Discharge Capacity (Ah) @ 1C vs. Voltage (V) at various temperatures

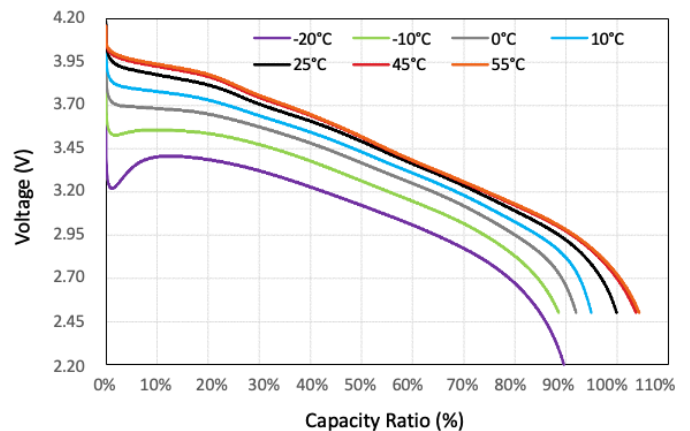

Technical Data Sheet | AMP-TDS-SA17-R2

Fremont, CA | inquire@amprius.com

©2024 Amprius Technologies, Inc. | www.amprius.com | All information is subject to change without notice

SA65

SiMaxx™ | Rechargeable Lithium-Ion Cell

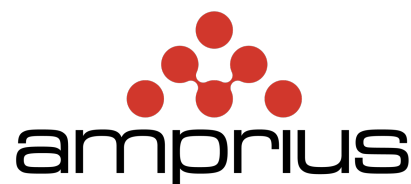

1.34 Ah Balanced Power + Energy Cell

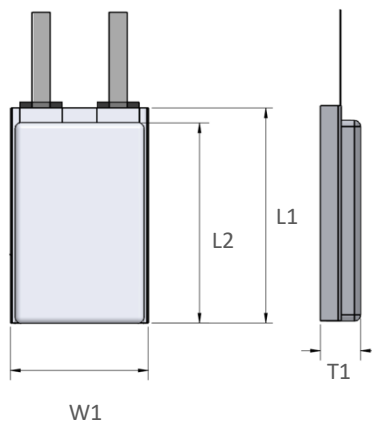

Specifications

Capacity	Typical @ C/5	1340 mAh
		4.62 Wh
	Minimum	1270 mAh
		4.38 Wh
Cell Voltage	Nominal	3.45 V
	Charge	4.25 V
	Discharge	2.50 V
Discharge Current	Max Continuous	5.1 A (4C)
	Max Pulse (≤ 30 seconds)	10.0 A (8C)
Charge Current	Typical	0.268 A (C/5)
	Maximum (0% to 100% SOC)	1.34 A (1C)
Temperature Range Ambient	Discharge	-10 to 50°C
	Charge	0 to 50°C
	Storage	-20 to 30°C
Internal Resistance	ACIR (1 kHz @ 30% SOC)	$\leq 45\text{m}\Omega$
	DCIR	100 m Ω
Cycle Life	+1C/-2C, to 80% SOH	150 cycles
Weight		11.7 \pm 0.5g
Packaging		Pouch
Cathode		NMC
Energy Density Including packaging	Gravimetric	395 Wh/kg
	Volumetric (@ 30% SOC)	800 Wh/l
Special Note	Cell requires external clamping of 30 PSI	
Certifications	UN 38.3	

Dimensions

Size	L1	37.0 \pm 1.0mm
	L2	33.5 \pm 0.55mm
	W1	22.4 \pm 0.5mm
	T1 (@ 30% SOC)	7.0 \pm 0.4mm

Technical Data Sheet | AMP-TDS-SA65-R3

Fremont, CA | inquire@amprius.com

©2024 Amprius Technologies, Inc. | www.amprius.com | All information is subject to change without notice

SA65

SiMaxx™ | Rechargeable Lithium-Ion Cell

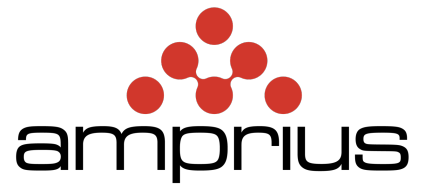

1.34 Ah Balanced Power + Energy Cell

Discharge Rate Capability

At Room Temperature

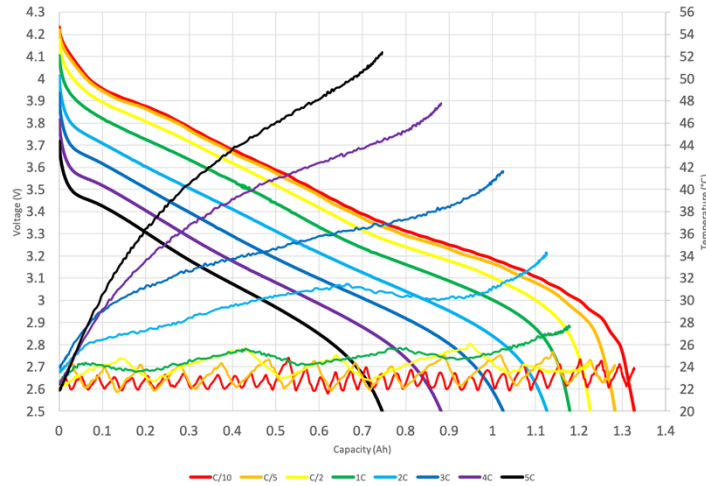

Cycle Life Performance

At Room Temperature

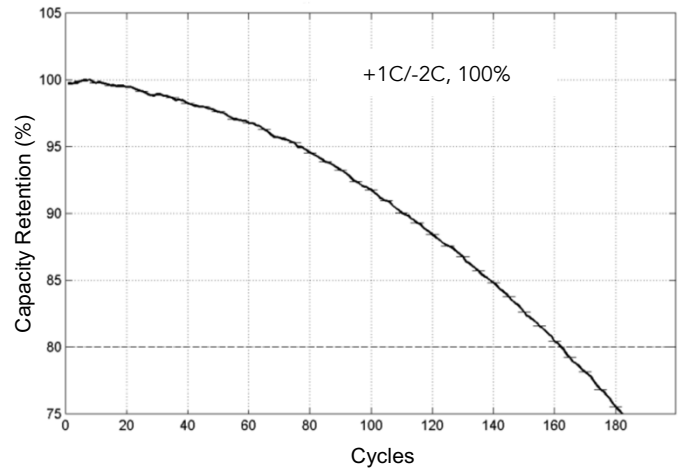

Charge Rate Profiles

C/5 and 1C Charge Rates

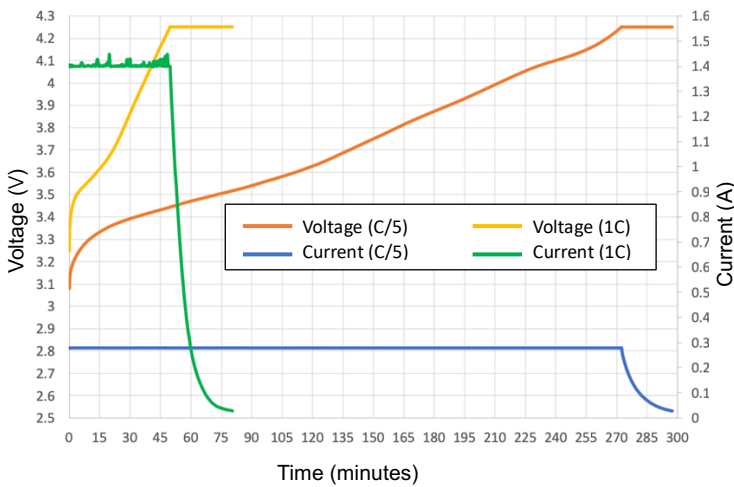

Technical Data Sheet | AMP-TDS-SA65-R3

Fremont, CA | inquire@amprius.com

©2024 Amprius Technologies, Inc. | www.amprius.com | All information is subject to change without notice

SA72

SiMaxx™ | Rechargeable Lithium-Ion Cell

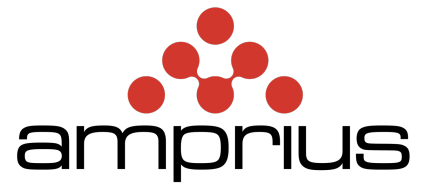

2.9 Ah High Power Cell with Fast Charging

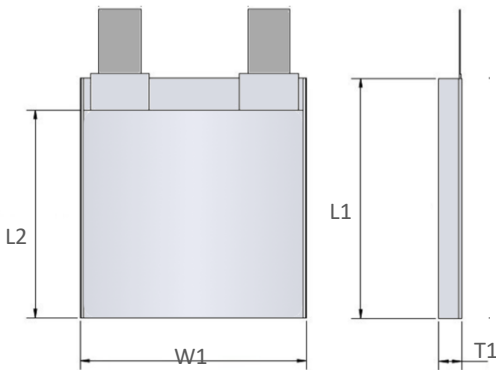

Specifications

Capacity	Typical @ C/5	2900 mAh
		9.86 Wh
	Minimum	2800 mAh
		9.52 Wh
Cell Voltage	Nominal	3.40 V
	Charge	4.25 V
	Discharge	2.50 V
Discharge Current	Max Continuous	17.4 A (6C)
	Max Pulse (≤ 30 seconds)	23.2 A (8C)
Charge Current	Typical	580 mA (C/5)
	Maximum (0% to 100% SOC)	17.4 A (6C)
Temperature Range Ambient	Discharge	-10 to 50°C
	Charge	0 to 50°C
	Storage	-20 to 30°C
Internal Resistance	ACIR (1 kHz @ 30% SOC)	≤ 15 m Ω
	DCIR (10 sec, 3C @ 30% SOC)	30 m Ω
Cycle Life	+1C/-3C, to 80% SOH	150 cycles
Weight		27.0 \pm 2g
Packaging		Pouch
Cathode		NMC
Energy Density Including packaging	Gravimetric	365 Wh/kg
	Volumetric (@ 30% SOC)	760 Wh/l
Special Note	Cell requires external clamping of 30 PSI	

Dimensions

Size	L1	56.6 \pm 1.0mm
	L2	52.6 \pm 0.9mm
	W1	50.0 \pm 1.0mm
	T1 (@ 30% SOC)	5.0 \pm 0.22mm

Technical Data Sheet | AMP-TDS-SA72-R2

Fremont, CA | inquire@amprius.com

©2024 Amprius Technologies, Inc. | www.amprius.com | All information is subject to change without notice

SA72

SiMaxx™ | Rechargeable Lithium-Ion Cell

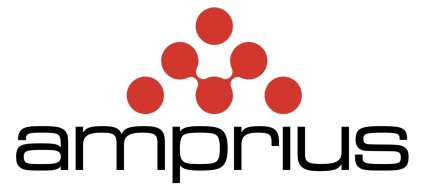

2.9 Ah High Power Cell with Fast Charging

Discharge Rate Capability

At Room Temperature

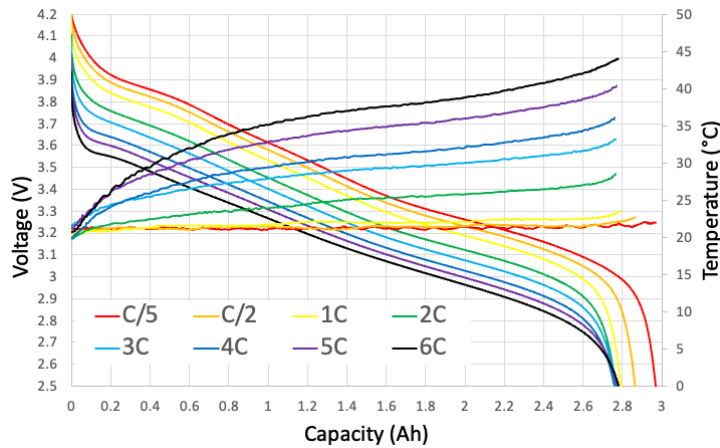

Cycle Life Performance

At Room Temperature

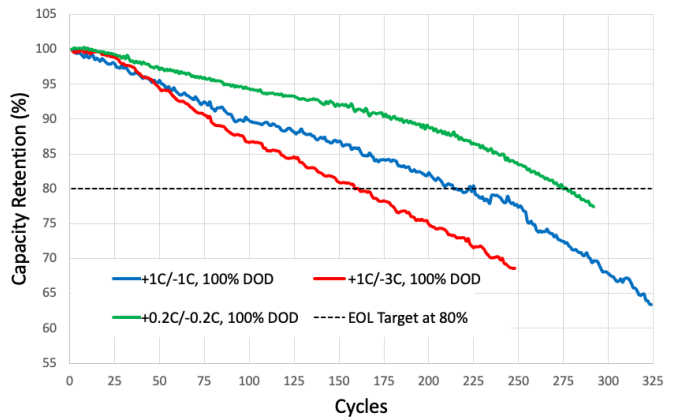

Charge Rate Profiles

Room Temperature at 6C & 10C; Fast Charge

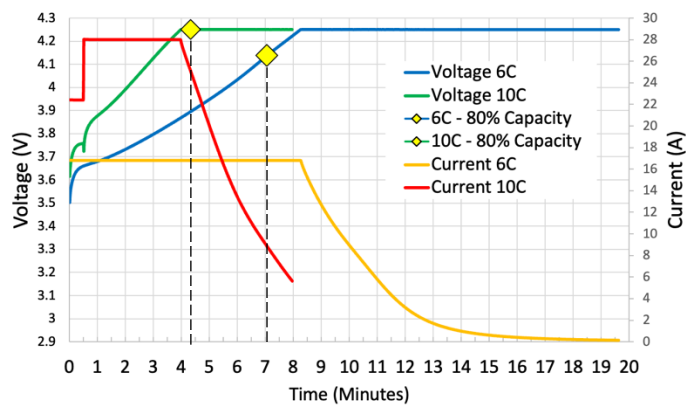

Technical Data Sheet | AMP-TDS-SA72-R2

Fremont, CA | inquire@amprius.com

©2024 Amprius Technologies, Inc. | www.amprius.com | All information is subject to change without notice

SA75

SiMaxx™ | Rechargeable Lithium-Ion Cell



11.8 Ah High Energy Cell

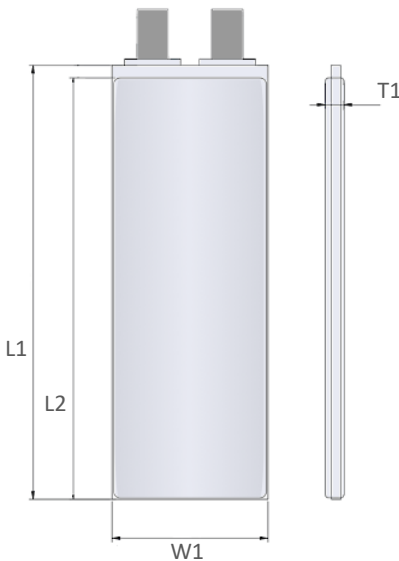

Specifications

Capacity	Typical @ C/10	11800 mAh
		40.7 Wh
	Minimum	11500 mAh
		40.6 Wh
Cell Voltage	Nominal	3.45 V
	Charge	4.20 V
	Discharge	2.50 V
Discharge Current	Max Continuous	11.8 A (1C)
	Max Pulse (≤ 30 seconds)	23.6 A (2C)
Charge Current	Typical	2.36A (C/5)
	Maximum (0% to 100% SOC)	11.8 A (1C)
Temperature Range Ambient	Discharge	-20 to 50°C
	Charge	10 to 45°C
	Storage	-20 to 30°C
Internal Resistance	ACIR (1 kHz @ 30% SOC)	20 m Ω
	DCIR	N/A
Cycle Life	+0.2C/-0.2C, 100% DOD to 80% SOH	150 cycles
Weight		90.0 \pm 2g
Packaging		Pouch
Cathode		NMCA
Energy Density Including packaging	Gravimetric	450 Wh/kg
	Volumetric (@ 30% SOC)	1100 Wh/l
Special Note	Cell requires external clamping of 30 PSI	
Certifications	UN 38.3	

Dimensions

Size	L1	127.0 \pm 1.5mm
	L2	123.5 \pm 1.5mm
	W1	53.5 \pm 1.5mm
	T1 (@ 30% SOC)	5.5 \pm 0.40mm

Technical Data Sheet | AMP-TDS-SA75-P2

Fremont, CA | inquire@ampricus.com

©2024 Ampricus Technologies, Inc. | www.ampricus.com | All information is subject to change without notice

SA75

SiMaxx™ | Rechargeable Lithium-Ion Cell



11.8 Ah High Energy Cell

Discharge Rate Capability

At Room Temperature

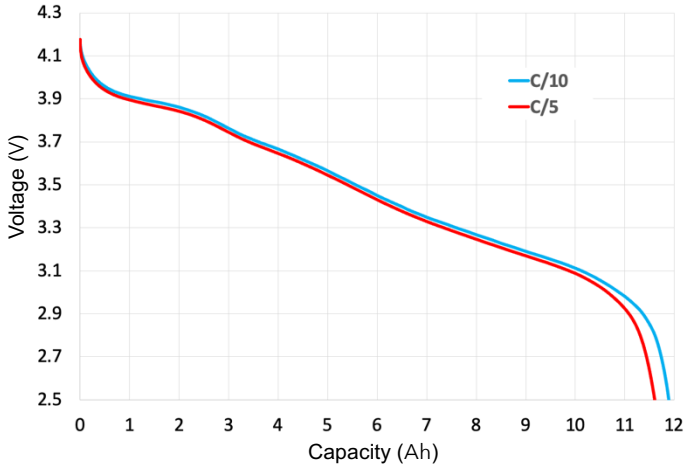

Cycle Life Performance

At Room Temperature

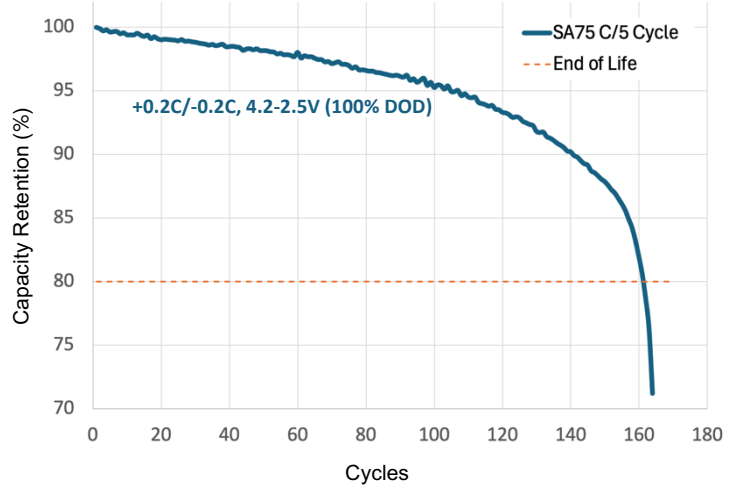

Charge Rate Profiles

Room Temperature at C/10 and C/5 Rates

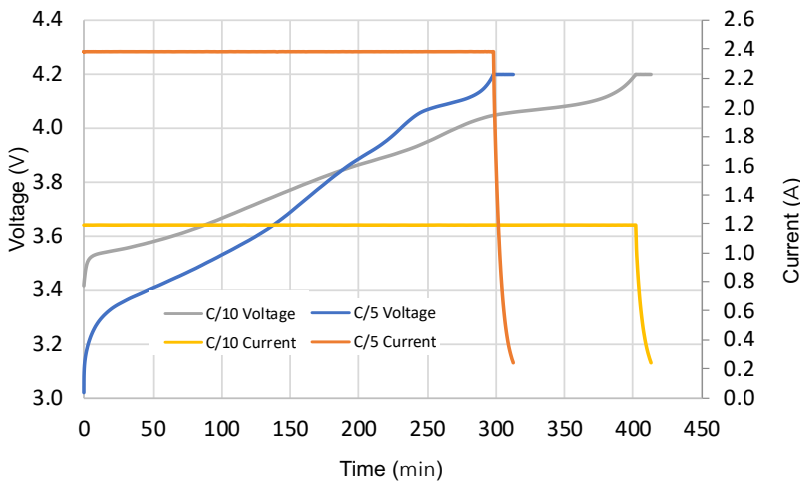

Technical Data Sheet | AMP-TDS-SA75-P2

Fremont, CA | inquire@amprius.com

©2024 Amprius Technologies, Inc. | www.amprius.com | All information is subject to change without notice

SA76

SiMaxx™ | Rechargeable Lithium-Ion Cell



4.2 Ah High Energy Cell



Specifications

Capacity	Typical @ C/10	4200 mAh
		14.5 Wh
	Minimum	4000 mAh
		14.0 Wh
Cell Voltage	Nominal	3.45 V
	Charge	4.20 V
	Discharge	2.50 V
Discharge Current	Max Continuous	4.2 A (1C)
	Max Pulse (≤ 30 seconds)	8.4 A (2C)
Charge Current	Typical	0.84 A (C/5)
	Maximum (0% to 100% SOC)	4.20 A (1C)
Temperature Range Ambient	Discharge	-20 to 50°C
	Charge	10 to 45°C
	Storage	-20 to 30°C
Internal Resistance	ACIR, 1 kHz @ 30% SOC	≤ 40 m Ω
	DCIR @ 30% SOC, 1C	≤ 36 m Ω
Cycle Life	+0.2C/-0.2C, to 80% SOH	150 cycles
Weight		32 \pm 1g
Packaging		Pouch
Cathode		NMCA
Energy Density Including packaging	Gravimetric	450 Wh/kg
	Volumetric (@ 30% SOC)	990 Wh/L
Special Note	Cell requires external clamping of 30 PSI	
Certifications	UN 38.3	

Dimensions

Size	L1	56.5 \pm 1.5mm
	L2	52.5 \pm 1.5mm
	W1	49.5 \pm 1.5mm
	T1 (@ 30% SOC, Fresh)	5.3 \pm 0.4mm

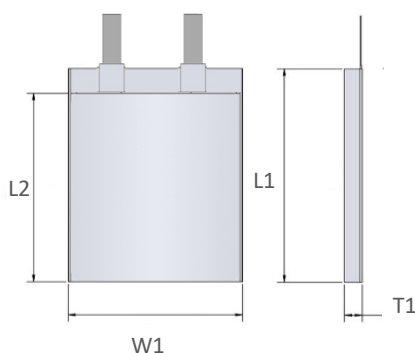

Technical Data Sheet | AMP-TDS-SA76-P2

Fremont, CA | inquire@amprius.com

©2024 Amprius Technologies, Inc. | www.amprius.com | All information is subject to change without notice

SA76

SiMaxx™ | Rechargeable Lithium-Ion Cell

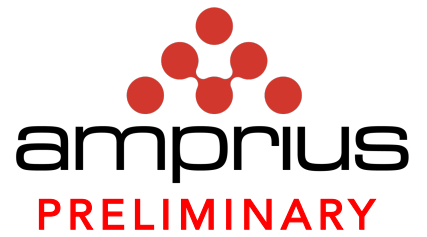

4.2 Ah High Energy Cell

Discharge Rate Capability

At Room Temperature

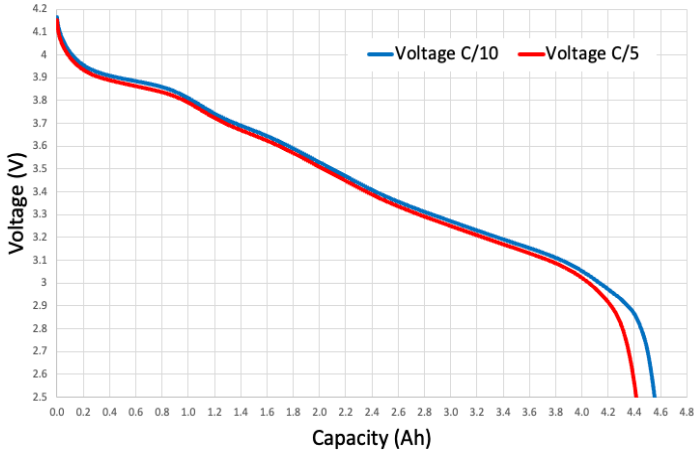

Cycle Life Performance

At Room Temperature

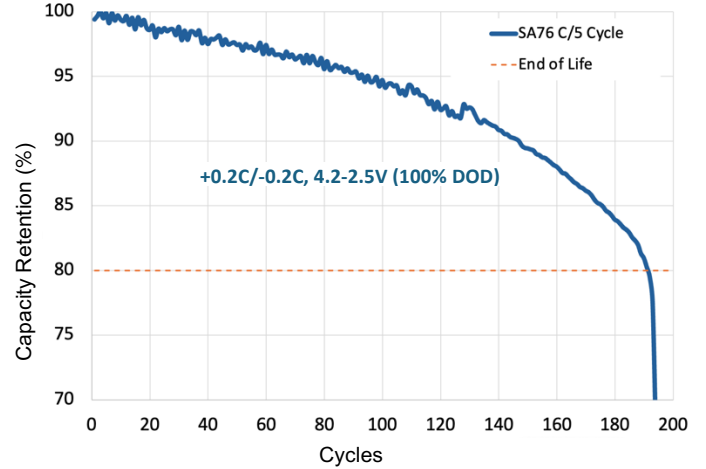

Charge Rate Profiles

Room Temperature

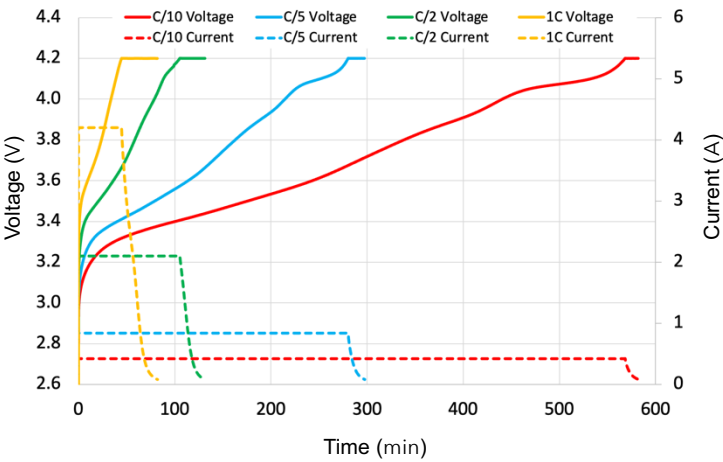

SA77

SiMaxx™ | Rechargeable Lithium-Ion Cell



5.8 Ah High Energy Cell



Specifications

Capacity	Typical @ C/10	5800 mAh
		20.0 Wh
	Minimum	5660 mAh
		19.4 Wh
Cell Voltage	Nominal	3.46 V
	Charge	4.20 V
	Discharge	2.50 V
Discharge Current	Max Continuous	5.8 A (1C)
	Max Pulse (≤ 30 seconds)	11.6 A (2C)
Charge Current	Typical	1.16 A (C/5)
	Maximum (0% to 100% SOC)	5.8 A (1C)
Temperature Range Ambient	Discharge	-20 to 50°C
	Charge	10 to 45°C
	Storage	-20 to 30°C
Internal Resistance	ACIR (1 kHz @ 30% SOC)	≤ 22 m Ω
	DCIR	N/A
Cycle Life	+0.2C/-0.2C, to 80% SOH	150 cycles
Weight		44.5 \pm 1g
Packaging		Pouch
Cathode		NMCA
Energy Density Including packaging	Gravimetric	450 Wh/kg
	Volumetric (@ 30% SOC)	1050 Wh/L
Special Note	Cell requires external clamping of 30 PSI	
Certifications	UN 38.3	

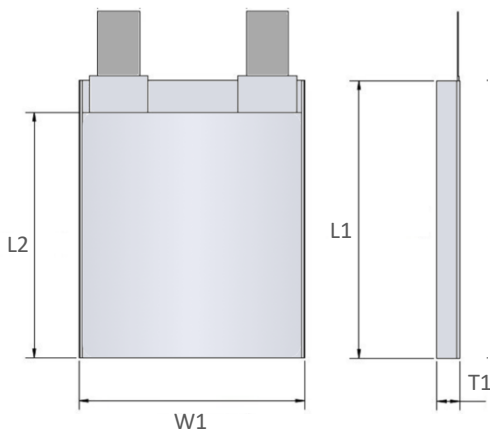

Dimensions

Size	L1	65.5 \pm 1.5mm
	L2	62.3 \pm 1.5mm
	W1	53.5 \pm 1.5mm
	T1 (@ 30% SOC)	5.70 \pm 0.40mm

Technical Data Sheet | AMP-TDS-SA77-P2

Fremont, CA | inquire@amprius.com

©2024 Amprius Technologies, Inc. | www.amprius.com | All information is subject to change without notice

SA77

SiMaxx™ | Rechargeable Lithium-Ion Cell



5.8 Ah High Energy Cell

Discharge Rate Capability

At Room Temperature

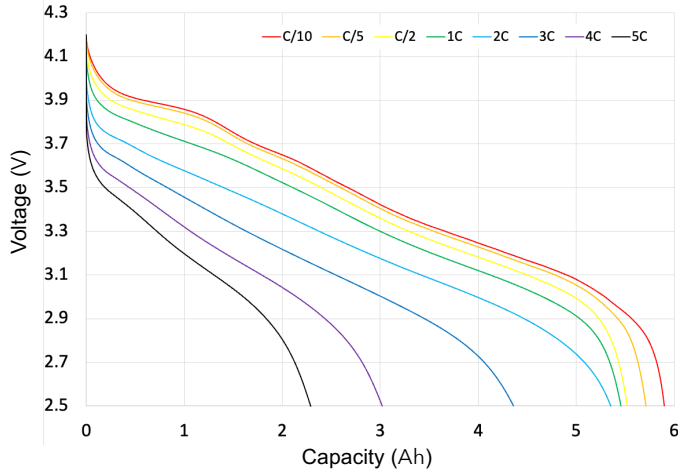

Cycle Life Performance

At Room Temperature

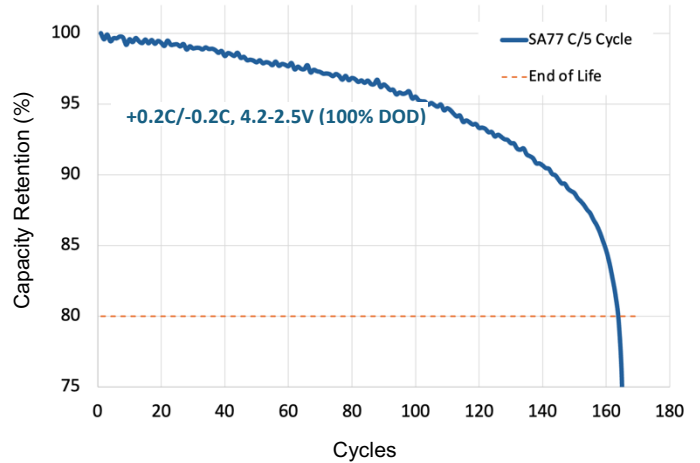

Charge Rate Profiles

At Room Temperature

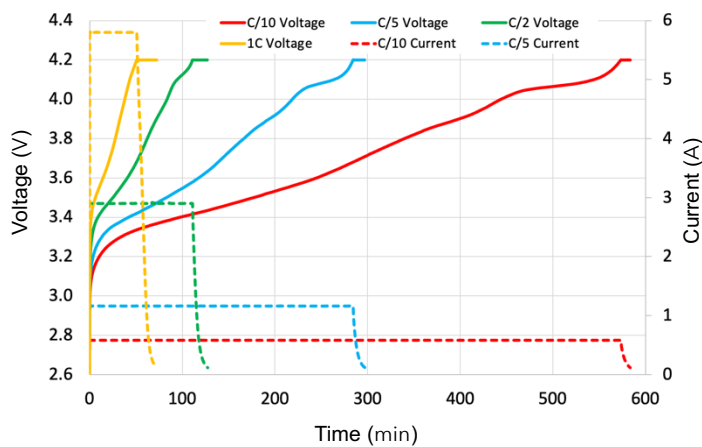

Technical Data Sheet | AMP-TDS-SA77-P2

Fremont, CA | inquire@ampricus.com

©2024 Ampricus Technologies, Inc. | www.ampricus.com | All information is subject to change without notice

SA80

SiMaxx™ | Rechargeable Lithium-Ion Cell



10 Ah Ultra-High Power, High Energy Cell with Fast Charging

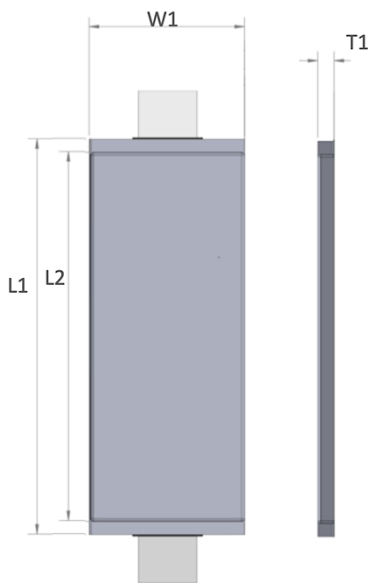

Specifications

Capacity	Typical @C/5	10000 mAh
		34.2 Wh
	Minimum	9750 mAh
		33.3 Wh
Cell Voltage	Nominal	3.42 V
	Charge	4.25 V
	Discharge	2.50 V
Discharge Current	Max Continuous	100 A (10C)
	Max Pulse (≤ 30 seconds)	150 A (15C)
Charge Current	Typical	60 A (6C)
	Maximum (0% to 100% SOC)	100 A (10C)
Temperature Range Ambient	Discharge	-10 to 50°C
	Charge	0 to 50°C
	Storage	-20 to 30°C
Internal Resistance	ACIR (1 kHz @ 30% SOC)	≤ 7 m Ω
	DCIR	N/A
Cycle Life	+1C /-3C, to 80% SOH	220 cycles
Weight		86.0 \pm 1g
Packaging		Pouch
Cathode		NMCA
Energy Density Including packaging	Gravimetric	400 Wh/kg
	Volumetric	820 Wh/l
Special Note	Cell requires external clamping of 30 PSI	

Dimensions

Size	L1	135.2 \pm 0.5 mm
	L2	126.2 \pm 0.4 mm
	W1	53.1 \pm 0.2 mm
	T1 (@ 30% SOC)	5.6 \pm 0.3 mm

Technical Data Sheet | AMP-TDS-SA80-P2

Fremont, CA | inquire@amprius.com

©2024 Amprius Technologies, Inc. | www.amprius.com | All information is subject to change without notice

SA80

SiMaxx™ | Rechargeable Lithium-Ion Cell



10 Ah Ultra-High Power, High Energy Cell with Fast Charging

Discharge Rate Capability

At Room Temperature

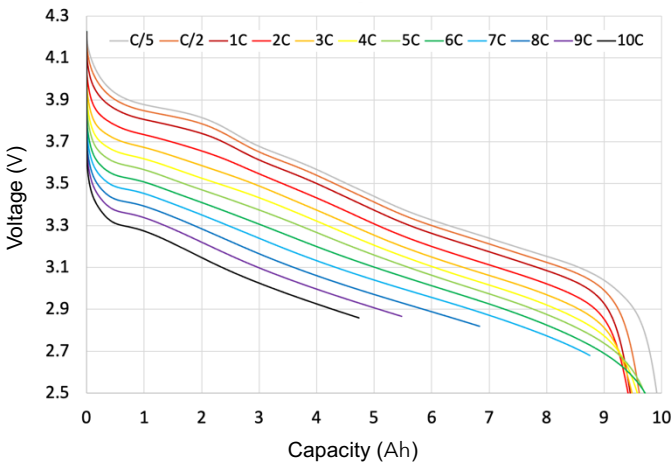

Cycle Life Performance

At Room Temperature

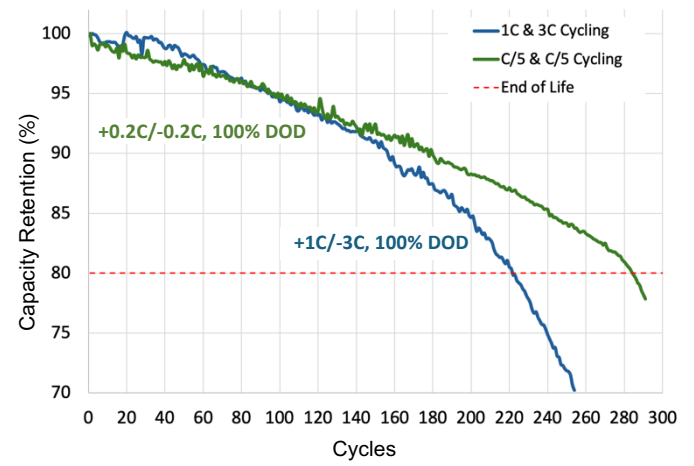

Charge Rate Profiles

At Room Temperature

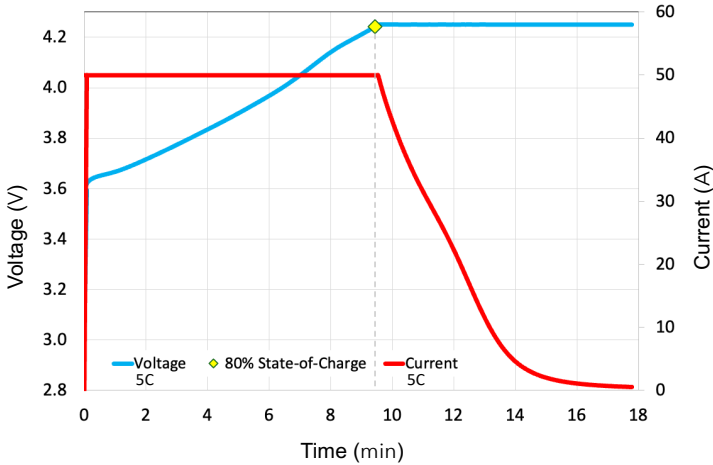

Technical Data Sheet | AMP-TDS-SA80-P2

Fremont, CA | inquire@amprius.com

©2024 Amprius Technologies, Inc. | www.amprius.com | All information is subject to change without notice



Get in touch.



www.amprius.com



Contact Sales at
inquire@amprius.com



1180 Page Ave.
Fremont, CA, USA

©2024 Amprius Technologies, Inc. | All information is subject to change without notice

Version 08.24